

Jet Towel™

High-speed Jet Hand Dryers



Jet Towel™ – The World’s First High-speed Hand Dryer

The Evolution of the Mitsubishi Electric Jet Towel

In 1992, new advances in compact DC brushless motor technology were developed at the Nakatsugawa Works, a Mitsubishi Electric factory located in Central Japan. While thinking of applications for the new motor, engineers came up with the novel idea of using high-powered jets of air to rapidly blow water off the hands instead of relying on evaporation like conventional electric dryers. As a result, the Jet Towel was officially released in 1993 and hand drying has not been the same ever since.

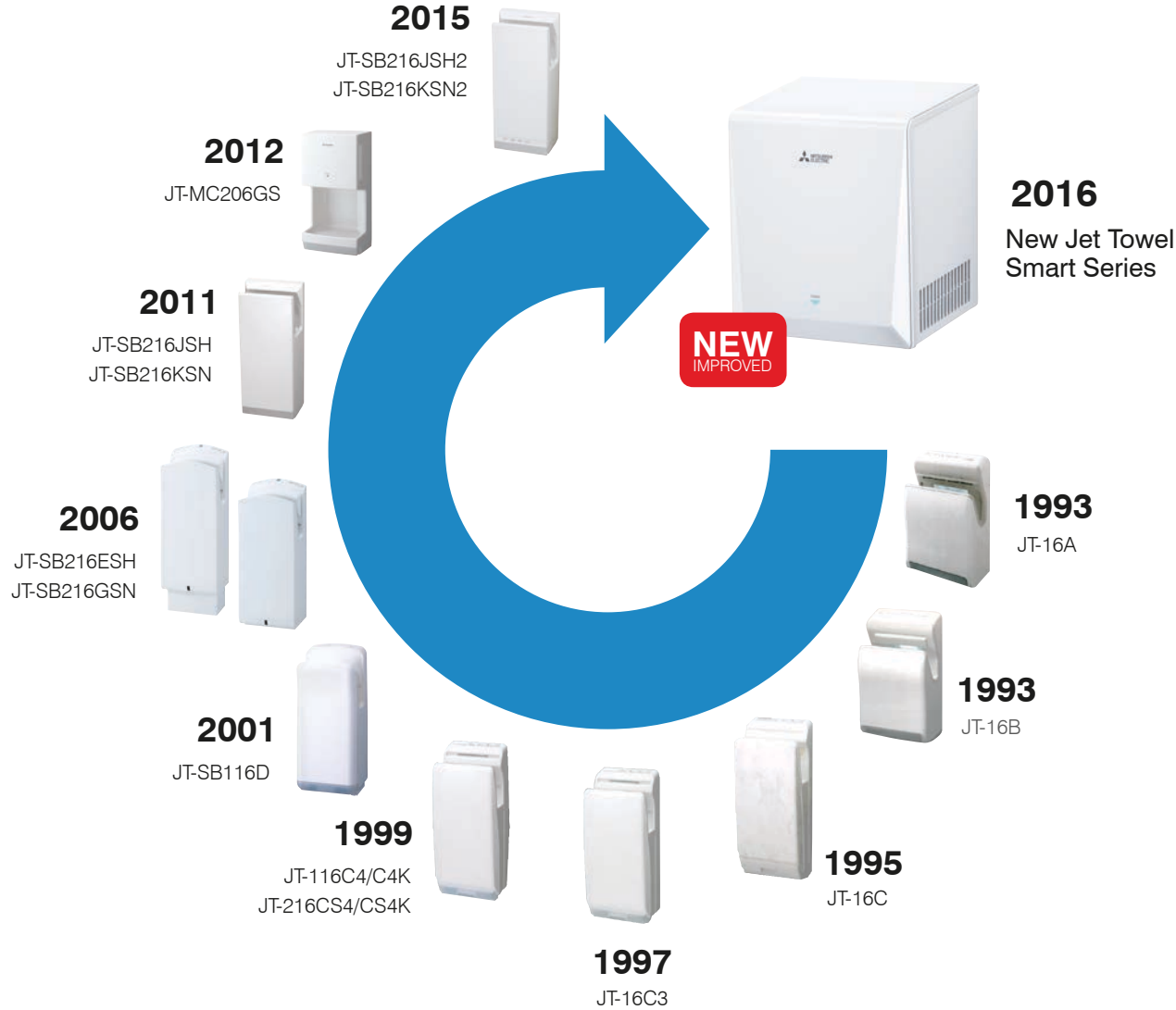

The Jet Towel Range Overview

Jet Towel Slim

This new model offers outstanding performance with a drying time of only 9–11 seconds, energy usage of 550W (standard speed setting) and a low noise operation of only 56dBA. As the 9th generation of the Jet Towel Slim, this latest model achieves a significant 2dBA reduction in noise; bringing increased quietness to washrooms. As the pioneer of high-speed hand drying, Mitsubishi Electric understands that air speed is only one factor contributing to energy efficiency and improved performance. To ensure the successful advancement of the Jet Towel, Mitsubishi Electric is resolute in researching smarter nozzle designs and finding the perfect balance between air speed and volume; for even greater efficiencies. This, combined with the high quality and reliability you can expect from Mitsubishi Electric, makes Jet Towel a worthy investment.



JT-SB216JSH2

Available in White/Silver/Grey



Jet Towel Smart

The engineers at Mitsubishi Electric have simultaneously achieved an amazing 9–12 seconds drying performance and the lowest power consumption in Jet Towel history with the new Jet Towel Smart hand dryer. With a generous 13.2cm space between the air nozzles and the wall, there is more than enough space to accommodate for hands of all sizes. Optimised sensors react with precision to ensure drying operation begins as quickly as possible; taking less than 0.1 seconds for the Jet Towel to detect hands and begin dispensing air. Jet Towel Smart is available in both White and Silver, and is also available in customised colours for large orders. Your company logo can also be added to the unit; providing a unique way to promote awareness of your business with a signature look.



JT-S2AP

Available in White/Silver/Custom



Jet Towel Mini

The Greener Choice – Eliminate the Costs of Paper Towel Maintenance



ECONOMICAL

96% COST REDUCTION*

Assumptions: 1. Electricity rate of \$0.27/kWh, 2. 2 paper towels consumed per use, at \$0.01/towel. Excludes cleaning and paper garbage disposal costs.



GREEN

ZERO WASTE

Economical

The cost of constantly replacing paper towels each day can be staggering. Because the Jet Towel only uses electricity to operate, operating costs are significantly lower.

Eco-Friendly

The Jet Towel does not create any waste, eliminating the trouble of waste disposal and conserving forest resources at the same time. Switching to the Jet Towel sends a positive message to users about a facility's attitude towards the environment.

Easy Maintenance

Paper towels need to be constantly refilled and paper garbage removed throughout the day. Jet Towels require minimal maintenance, freeing up service staff to focus on other tasks.

High User Satisfaction

Empty paper towel dispensers and overflowing garbage cans create a negative impression on restroom users. Jet Towels never "run out" and can dry hands in approximately the same amount of time.

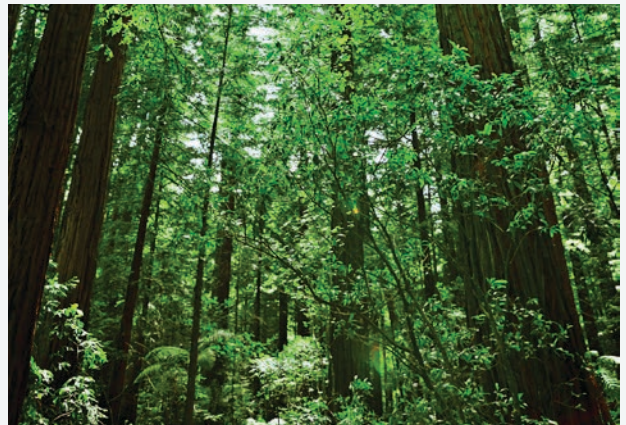

* Calculated with JT-SB216JSH2.

Mitsubishi Electric Quality – the Difference is in the Details

Certified by NSF International

NSF International, an independent third-party public safety health and standards organisation, has certified Jet Towels to be compliant to its rigorous requirements (NSF/ANSI 169).



Antibacterial Plastics

The plastics used in Jet Towels curb the growth of bacteria on the surface. The secret is the metal ions added into the resin, which work to inhibit bacteria and reproductive growth.

No Touch Design

Jet Towels are activated automatically when hands pass through infrared sensors in the spacious drying area. Compared to other brands, Jet Towels are designed with lower airspeeds to avoid blowing users' hands against the wall of the unit.

Safe for Alcohol Cleaning*

Normal plastics react with alcohol, which can result in cracking and damage. Jet Towels use high-grade plastic that can be safely cleaned with cleansers containing alcohol (less than 83% ethanol content).

Comparative Proof of Antibacterial Effect

Following 24hr culturing using a film contact method in Mitsubishi Electric laboratories. Silver ions attach to the cell walls of general cellular bacteria, curbing protein synthesis and reaction to control bacterial growth and reproduction.

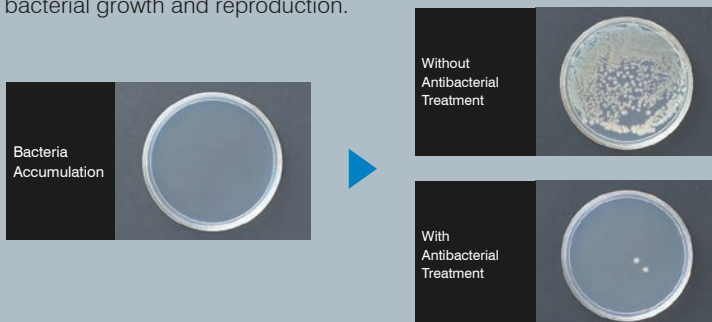

* Excluding the front panels of JT-SB216JSH2-S-NE and JT-S2AP-S-NE

High Quality Motor

The high-precision motors used in Jet Towels are developed and manufactured to strict specifications set by Mitsubishi Electric. In-house testing results estimate a motor life of over seven years for the Slim, Smart and Mini models.*

Separated Air Intake

In all models, the air intake is located separately from the output nozzles to reduce the risk of water intake.

Metal Enclosure

High-voltage circuit boards are completely covered by a protective metal enclosure. In the highly unlikely event of a fire occurring, flames are sealed in and cannot spread outside of the barrier.

Fire-resistant Parts

Internal parts are made from flame-resistant UL94V-0 and UL94V-5VA-grade materials to prevent fire.

Temperature and Current Fuses

Multiple fuses located throughout the unit protect the user from over-current and over-heating. Operation is halted instantly if conditions are abnormal.

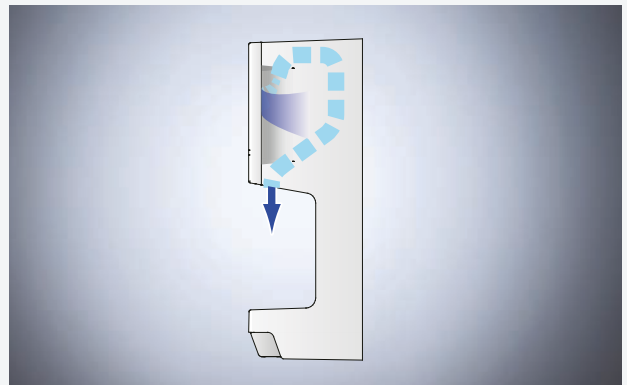

| Jet Towel Model | NSF Certified | Antibacterial plastic | No-touch Design | Alcohol Safe | Drain Tank | Motor Type | Metal Circuit Board Enclosure | Fire Resistant Parts | Safety Fuses |
|-----------------|---------------|-----------------------|-----------------|--------------|------------|---------------|-------------------------------|----------------------|---------------------------|
| Slim | ● | ● | ● | ● | ● | DC Brushless | ● | ● | Thermal and Current Fuses |
| Smart | ● | ● | ● | ● | | AC Commutator | ● | ● | |
| Mini | | ● | ● | ● | ● | AC Commutator | ● | ● | |

* Motor life varies with frequency of use. Estimates calculated based on 400 users per day for JT SB216JSH2, 200 uses per day for JT-MC206GS, and 120 uses per day for JT-S2AP.

Jet Towel Slim

The New 9th Generation of the Original Dual-Jet Hand Dryer



White



Silver



Grey

New Wave Nozzle 2.0

Mitsubishi Electric's patented wave nozzle design has been further improved. Developed using fluid control technology, turbulence which increases sound has been decreased to achieve a reduction in noise by 2dBA.

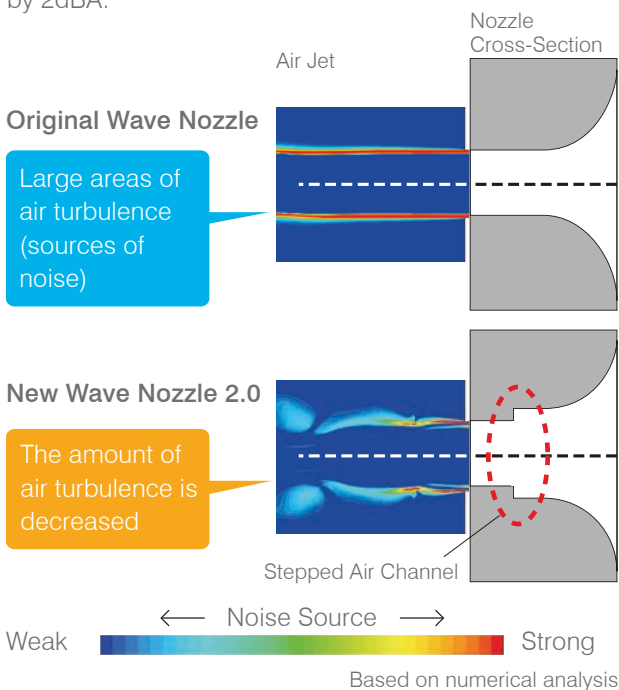

Large 6.8L Drying Area

The space to insert hands is a wide 7.7cm at the narrowest point and 20.8cm deep. The large drying area makes it easier to dry hands without touching the unit.

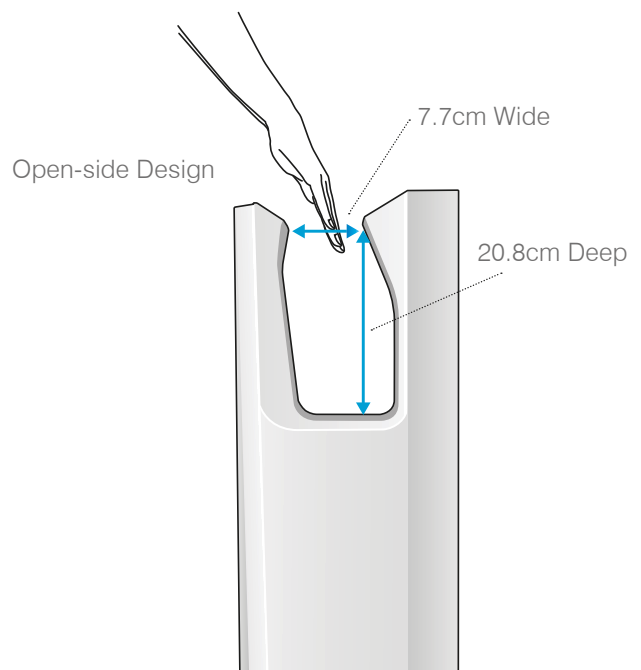

Child-friendly Design

Alternate child sensors are placed inside of the drying area to detect small hands entering from the sides.

High-efficiency Brushless DC Motor

This high-precision motor is developed and manufactured entirely by Mitsubishi Electric. In-house testing results show a motor life of over seven years of use (400 uses per day).

Reinforced Protective Panels

Newly designed front and back panels make the new Jet Towel Slim more robust and impact-resistant. The protective steel outer shell and ABS plastic body are designed to sustain moderate impact, and tested to withstand a greater amount of force than previous models.

Easy Access Air Filter and Drain Duct

The washable air filter and drain duct are easily accessible, making quick and thorough cleaning possible. No tools or time-consuming disassembly required.

0.8L Drain Tank Keeps Floors Dry



Water blown from hands is caught and channeled into a convenient drain tank for easy removal. It stores up to approximately 800 uses (0.8L), and requires only periodic emptying and quick rinsing. In the 9th generation model, the drain tank is the same color as the body, making it less conspicuous to prevent tampering.

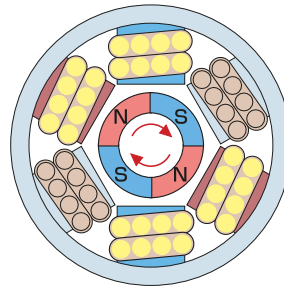

Brushless DC Motor with contact-free rotor eliminates wear and tear.

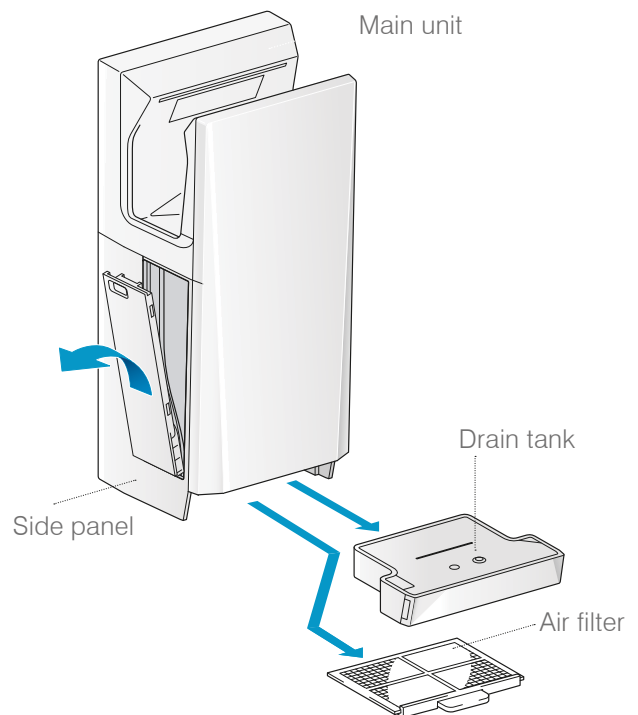

A small window indicates the level of water collected.



*1 Excluding front panel of JT-SB216JSH2-S-NE *2 Available for JT-SB216JSH2

Jet Towel Smart

The Latest Model of the Original Dual-Jet Hand Dryer



White



Silver

Smart Drying

Industry Top-class Drying Performance and Energy Efficiency

The engineers at Mitsubishi Electric have simultaneously achieved an amazing 9–12 seconds drying performance and the lowest power consumption in Jet Towel history.

| | Jet Towel Slim | Jet Towel Mini | Jet Towel Smart |
|-----------------------------------|----------------|----------------|-----------------|
| Energy Consumption (Per 100 uses) | 0.31 kWh | 0.30 kWh | 0.25 kWh |

Energy consumption calculated with the following assumptions: input voltage of 240V, heater on, and at high power settings. Standby power consumption not included in calculation.

Tough Exterior

The protective steel outer shell and ABS plastic body are designed to sustain moderate impact, and tested to withstand a greater amount of force than previous models.

The IPX-3 rating for water resistance means that it is also protected against moisture infiltration from spraying water.



Large Drying Area

With a generous 13.2cm space between the air nozzles and the wall, there is more than enough space to accommodate hands of all sizes.

0.1 Second Quick Response

Optimised sensors react quickly to ensure drying operation begins as quickly as possible, taking less than 0.1 seconds for the Jet Towel to detect hands and begin dispensing air.

15cm Wide Nozzle

The wide nozzle design spreads airflow across a large area, ensuring both hands are dried at the same time.

Smart Tilted Roof Design

The top of the Jet Towel Smart is tilted at a 12° angle to prevent users from leaving unwanted trash and other objects on the unit.

Easy Air Filter Maintenance

The air filter is an important component as it prevents excess dust and dirt from accumulating inside of the unit. The filter is placed conveniently up against the side of the intake grill, allowing for quick cleaning without any disassembly required.

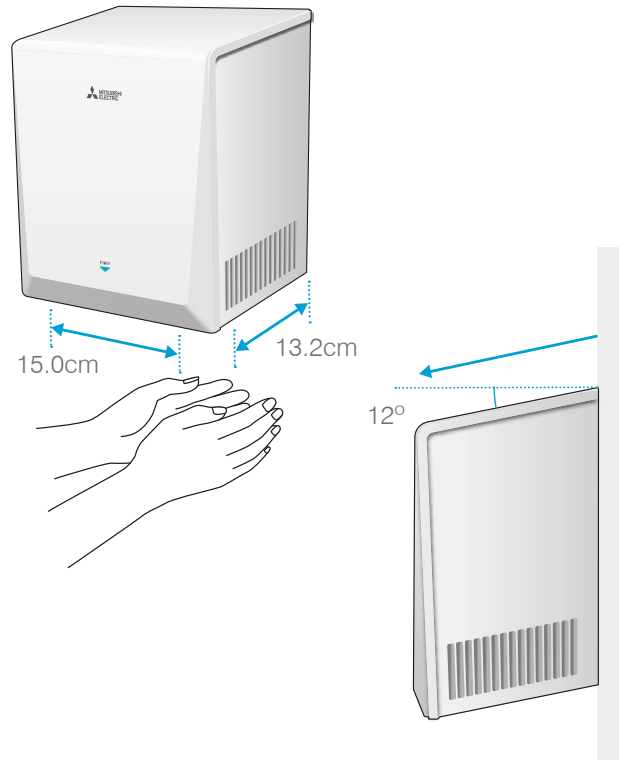

Customised Colour Options Available

Jet Towel Smart is available in customised colours for large orders. Your company logo can also be added to give each unit a signature look, providing a unique way to promote awareness of your business.

Customisation options are – custom logo, custom front panel colour and custom body colour.



Antibacterial Surfaces*¹

Designed for Alcohol-based Cleaners*¹

Quiet Operation 58dBA

Robust Design

Quick Start 0.1 Second Response

Protective Steel Shell*²

PTC Heater*²

*1 Excluding front panel of JT-S2AP *2 Available for JT-S2AP models

Model Dimensions

Jet Towel Slim – JT-SB216JSH2

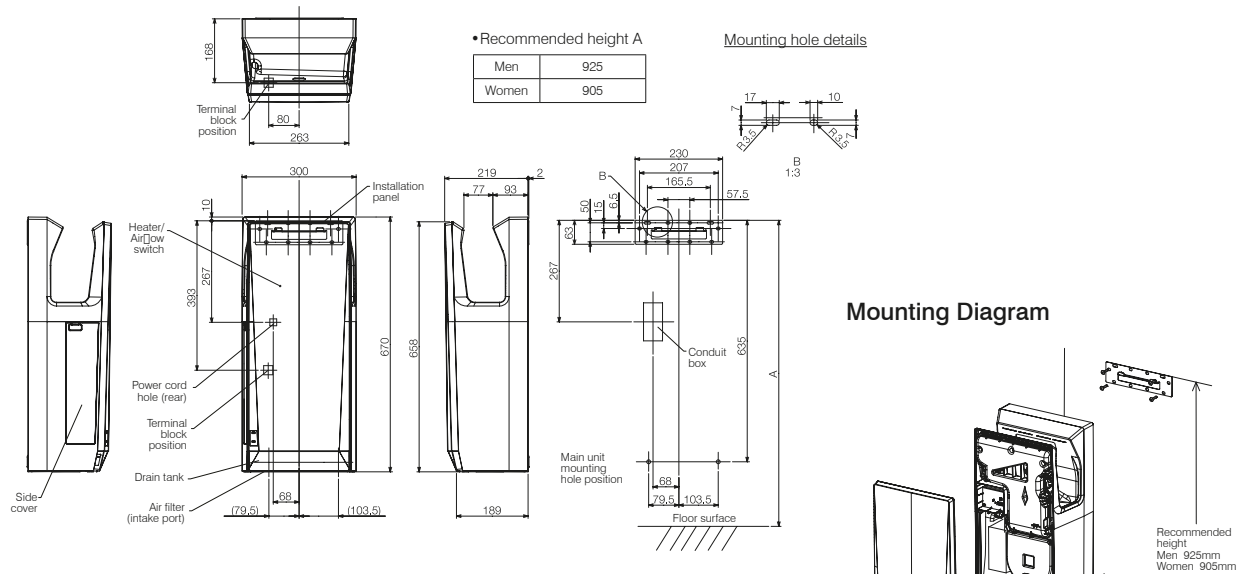

- For fastening main unit mounting screws, use a Phillips(+) screwdriver with a shaft length of at least 150mm.
- Mount the unit so that the left-side cover is removable and the rating label is visible. (At least 150mm, but 200mm or more is recommended. Embedded portion is excluded.) Allow 200mm or more to enable the water drainage duct to be checked after cleaning.
- Allow at least 130mm between the bottom surface (air-intake port) of the unit and the door surface.

(Unit: mm)

Jet Towel SMart – JT-S2AP

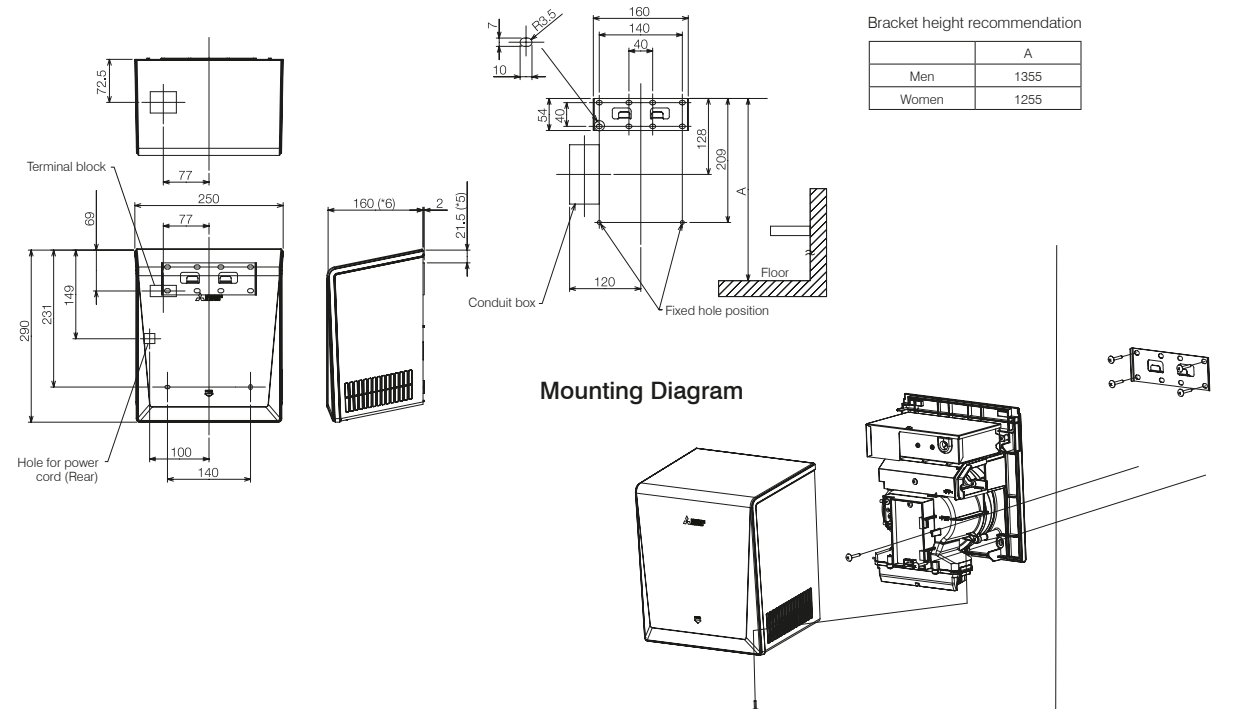

- Please ensure that both sides of the unit are at least 100mm from all obstacles, including the wall.

(Unit: mm)

Model Specifications

| Model | Power Supply | Mode | Heater | Drying Time (sec) ^{*1} | Power Consumption (W) | Noise (dBA) ^{*2} | Motor Type | Hygienic Features | External Dim. (mm) | Weight (kg) | Drain Tank (L) | |
|--|-------------------------------------|-------------------------------------|--------|---------------------------------|-----------------------|---------------------------|-----------------|---|-------------------------|-------------|----------------|--|
| Jet Towel Slim JT-SB216 JSH2 | 220-240V 50-60Hz Single phase | High | ON | 9-11 | 1240 | 59 | Brushless DC | Antibacterial surfaces - NSF certification - Alcohol cleanable | W 300 D 219 H 670 | 11 | 0.8 | |
| | | | OFF | 11-13 | 720 | | | | | | | |
| | | Std | ON | 11-13 | 1070 | 56 | | | | | | |
| | | | OFF | 13-15 | 550 | | | | | | | |
| Jet Towel Smart JT-S2AP (Metal Cover) | | 220-240V 50-60Hz Single phase | High | ON | 9-12 | 880-980 | 60-62 | | Commutator | | | |
| | | | | OFF | 10-13 | 630-730 | | | | | | |
| | | | Std | ON | 14-16 | 660-740 | 58-59 | | | | | |
| | | | | OFF | 15-17 | 410-490 | | | | | | |
| <p>^{*1} Time needed to reduce remaining water to 50mg or less per hand (in-house study).</p> <p>^{*2} Measurements made in anechoic chamber at a distance of 2m.</p> <p>^{*3} Jet Towel Smart Lite available only in white.</p> | | | | | | | | | | | | |